

# UNDERSTANDING POLICYMAKING IN INDONESIA: IN SEARCH OF A POLICY CYCLE

---

Study by The Policy Lab (The University of Melbourne) and the Indonesian Centre for Law and Policy Studies (PSHK), for Knowledge Sector Initiative.



Authors: Emma Blomkamp, M. Nur Sholikin, Fajri Nursyamsi, Jenny M. Lewis and Tessa Toumbourou

June 2017

## Key Messages

- The model of a policy cycle – a sequential process where policy is developed in a logical manner in response to a perceived problem – is criticised by scholars and practitioners for its underlying assumption that decision making is rational and orderly.
- Within literature on policymaking and politics in Indonesia, scholars identify actors, activities and patterns of policymaking that challenge straightforward notions of a policy cycle.
- Evidence from this study suggests that the steps of the policy cycle - from agenda setting to policy evaluation – do not align with the actual practice of policymaking in Indonesia. Some stages in the policy cycle, such as consultation and evaluation by the state, were not prominent in practice. Meanwhile, activities such as policy analysis, decision making and coordination were not conducted sequentially.
- The general process of policymaking in Indonesia cannot accurately be represented as a cycle, underpinned by the rationality of applied problem solving.
- Gaining a better understanding of the policy networks and practices that exist in Indonesia could further uncover who is involved in the process, what evidence they use, and how they are able to shape debates on particular issues.
- Greater understanding of the policy process in Indonesia could help KSI and the broader knowledge sector in Indonesia to identify windows of opportunity for knowledge mobilisation.

## Table of Contents

Executive Summary .....	4
1. Introduction .....	6
2. Methodology.....	7
3. The concept of the policy cycle.....	9
4. Policymaking in Indonesia: structures and traditions.....	13
5. Indonesian policymaking in practice: actual examples of policy processes .....	21
6. Discussion: is there an Indonesian policy cycle? .....	30
7. Conclusion.....	34
8. References.....	36
Annex: list of experts consulted.....	39

## Executive Summary

Public policymaking is widely understood as a structured and logical process of problem solving led by the government. But is there really a 'policy cycle' in practice? In the context of Indonesia's complex policy challenges and political contestation, is it feasible to speak of such a cycle? The aim of the paper is to provide a more informed understanding of how policymaking works in practice in Indonesia, and to explore the relevance of the policy cycle model in this context. The Policy Lab at The University of Melbourne, in collaboration with PSHK - the Indonesian Centre for Law and Policy Studies - led this study on the policymaking process in Indonesia for the Knowledge Sector Initiative (KSI) from April to June 2017.

This paper draws on academic and practice-based literature, consultation with experts on public policy in Indonesia, and six vignettes of different types of policy process. The paper supplements existing knowledge with greater attention to the development and implementation of policy in Indonesia. The model of a policy cycle – a sequential process where policy is developed logically in response to a perceived problem – is criticised by scholars and practitioners for the assumption that decision making is purely rational. Policy making takes place in complex political environments, where distinct stages in the policy cycle may not be evident, may overlap or be intertwined, and in some cases may be missing entirely. Meanwhile, within Indonesia, scholars identify the roles of actors at different levels (national and subnational) within and outside government, as well as policy activities and patterns of decision making that challenge straightforward notions of a policy cycle.

This paper examines instances of policymaking in Indonesia by all three branches of government – the executive, legislature and judiciary – as well as highlighting input from non-governmental actors. The selected six examples of policymaking relate to the Civil Service Law, management of traffic violation cases, establishment of the small claims procedure, Law on Persons with Disabilities, research procurement regulation, and Village Law. The paper describes how policy activities aligned, and did not align, with the policy cycle as an eight step process from agenda setting to policy evaluation.

The strongest pattern in the examples is an agenda-setting phase at the start of the policymaking process. Civil society organisations and the media appear to play a particularly important role in creating public awareness of issues. While the executive is often assumed to play a key role in policy analysis and formulation, in these examples they were more likely to be performed by the legislative branch or non-governmental actors. There was little evidence that the government would first analyse an issue before a policy decision would be made. In addition, policy instruments tended not to be designed based on the most rational means to achieve a high level strategy. Rather, the instruments seemed to be selected before any policy analysis took place. Further, consultation about policy was often not between citizens and the state, but rather through internal government actors consulting with each other, or civil society organisations leading public discussions with particular communities or stakeholders. Policy coordination did not necessarily wait until a policy document had been prepared. Rather than there being a single point of policy decision making, our examples demonstrate many points of decision, which represent different 'gates' through which a law must pass before becoming an enacted policy. Even after a law has been approved by Parliament and the President, it may not be implemented completely. One aspect of a policy may be implemented, for instance, while the broader approach stalls. Finally, our examples show very little policy evaluation and monitoring, except that done by non-governmental organisations.

The general process of policymaking in Indonesia cannot accurately be represented as a cycle underpinned by rational problem solving. Further investigation into the practice of policymaking in Indonesia should help to create a more nuanced picture of how policies are really made. Gaining a better understanding of Indonesian policy networks could further uncover who is involved in the process, what evidence they use, and how they are able to influence debates and negotiations on particular issues.

## 1. Introduction

Public policy is widely understood as a structured process of problem solving led by the government. Public policy textbooks often speak of the 'policy cycle' as though there is a natural or logical way for governments to make policy. But is there really a policy cycle in practice? Is it feasible - in a context of complexity and contestation - to speak of an Indonesian policy cycle? This study explores the relevance of this concept in the Indonesian context and seeks to explain key features of the policymaking process in Indonesia.

The Policy Lab at The University of Melbourne, in collaboration with PSHK - the Indonesian Centre for Law and Policy Studies, led this study on the policymaking process in Indonesia for the Knowledge Sector Initiative (KSI) from April to June 2017. KSI is a joint commitment between the governments of Indonesia and Australia to strengthen the quality of public policies through the better use of research, analysis and evidence. Key objectives for KSI, as it heads into its second five-year phase of operations, include a strengthened policy cycle in the Government of Indonesia, with improved demand for and use of evidence. For KSI, the term 'policy cycle' has been used as shorthand for 'policymaking process'.

In this paper, the 'policy cycle' is described as an academic concept underpinned by specific assumptions about how government operates. The term 'policy process' is used more broadly to refer to different perceptions of, and activities within, approaches to governmental decisions, actions, statements and artefacts.

The aim of the study is to provide a more informed understanding of how policymaking works in practice in Indonesia, and to explore the relevance of the 'policy cycle' model in this context. This paper presents the findings of a small study, drawing on relevant research and analysis already completed for KSI on policy-related processes in Indonesia, as well as secondary research and consultation with Indonesian government and policy experts and practitioners. It explores the uses, interpretations, limitations and applicability of the concept of the policy cycle in Indonesia. In particular, it considers existing knowledge of the development planning and budgeting processes, three branches of government, and significant policymaking activities at both the national and sub-national levels of government.

The paper is organised as follows:

- Section 2 presents the methodology of the study, noting how policy can be conceptualised.
- Section 3 discusses the concept of the policy cycle, drawing on a review of academic literature.
- Section 4 describes key features of the context of policymaking in Indonesia, paying particular attention to the structures and traditions of government.
- Section 5 presents several examples of the processes associated with developing (and, in some cases, implementing) a range of recent policies in Indonesia.
- Section 6 discusses common features of the policy processes depicted and relates them to the key concepts of the policy cycle model.
- Section 7 summarises the key findings of the study, noting implications and recommendations for KSI.

## 2. Methodology

Policymaking has formal and informal dimensions. Even a basic definition of public policy – ‘What government does and why it performs certain actions to address a public issue’ (Sullivan 2009, 424) – recognises that policy is more than what is officially written down. While public policy is determined by government, its development and application involves other actors and institutions too (Howlett and Mukherjee 2017, 3).

When policymaking is discussed and analysed in the Indonesian context (as elsewhere), observers and practitioners often focus on the formal dimensions of the policy process, such as legislation and regulation. Some may include planning as policy, but it is less common for them to speak of governmental behaviours as policy. There is very little academic literature on policymaking in Indonesia to support more nuanced understandings of this realm.

In practice, policymaking is shaped by dimensions of culture, power, capacity and relationships. The behaviours, or practices, of government are influenced by institutional structures and ideas, both of which are shaped by social and historical traditions (Bevir and Rhodes 2003; Schmidt 2010). This study acknowledges all these dimensions of the policymaking process, although its scope does not allow for a comprehensive review or exploration of policy practice in great depth. It has nonetheless been designed to recognise the multiplicity of actors and institutions involved, and various types of outputs that constitute public policy. This includes plans, legislation, regulation, the establishment of governmental agencies, presidential priorities, and funding decisions.

This study takes a practice-oriented policy sciences approach. It acknowledges that the policy process involves ‘many hands on the wheel, not all of them “government”,’ and that the governmental hands are ‘not necessarily steering in the same direction’ (Colebatch 2005, 15). It recognises ‘the limits to pure technical-rational thought’ and aims to develop practically useful knowledge (Durose and Richardson 2016, 12; Simon 1996).

Recent years have seen a small but growing body of studies emerge on Indonesian government and policy. Yet the actual process of policymaking has been neglected by academic onlookers (Sherlock 2012, 555) – a problem that plagues approaches to evidence-informed policy internationally (Huckel Schneider and Blyth 2017). This study builds on recent analyses of planning and policymaking in Indonesia, many of which take a political economy approach that highlights the complex institutional arrangements and power relationships shaping policy. This paper supplements existing knowledge with greater attention to the actual practice of policymaking, particularly by examining the development and implementation of specific instances of different types of policy.

This paper incorporates key findings from several other studies commissioned by KSI, along with a targeted literature review and expert consultation, in order to explore the concept of the policy cycle and the structures, traditions and practices that shape policymaking in Indonesia. Consultative meetings were held in Australia with experts and practitioners in Indonesian policy and government. Policy examples were developed based on a review of relevant documents and practice insights from the experience of PSHK in conducting research and advocacy related to policy. Four examples in this study were informed by direct experience of PSHK’s involvement in policy formulation: the management of traffic cases in court; small claims procedure; law on persons with disabilities; and research procurement

regulation. Two examples were developed through documentary sources only: the village law and civil service reform.

The paper presents these examples as vignettes, which are stories about individuals, situations and structures that draw on various sources and can be used to refer to important points about perceptions and behaviours (Hughes 1998, 381; Durose and Richardson 2016). The examples enable us to pinpoint specific activities that actually happened in the policymaking process, rather than a more general discussion that may be constrained by formal frames of policymaking, such as the 'policy cycle' model or Indonesian laws that stipulate how policy should be made.

This combination of academic and practice-based literature, expert consultation and policy vignettes enables our analysis to go beyond the 'policy cycle' and consider other ways of understanding the policy process in Indonesia.



### 3. The concept of the policy cycle

The policy cycle is a model or representation of the policymaking process as a sequential process, or cycle, where policy is developed in a logical process in response to a perceived problem (Lasswell 1956; Bridgman and Davis 1998). Of all approaches to, or models for, understanding the policy cycle, the rationalist, 'stages' model has become the dominant model for conceptualising the policy cycle (Bridgman and Davis 1998; Cairney 2012; Howlett, Ramesh, and Perl 2009; Sabatier and Jenkins-Smith 1993). The rationalist model was first developed by Lasswell (1956), as comprising a series of distinct but interrelated stages to be followed in the process of developing and enacting a public policy, underpinned by logic and the rationality of applied problem solving.

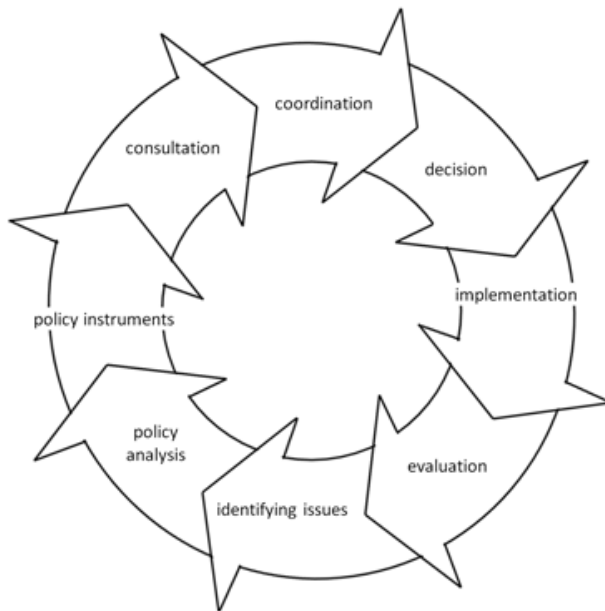

**Figure 1 The policy cycle stages model (based on Althaus et al. 2013)**

The stages model of the policy cycle remains commonly used as a prescriptive tool, outlining the steps that should be taken by policymakers to develop robust, evidence-based policy outcomes with broad application across all political systems. Some scholars, educators and practitioners find the model to be a useful heuristic device for describing a complicated, often messy process. Lasswell's (1956) early stages model of the policy cycle has since been amended and revised by various scholars. A more recent model of the policy cycle was developed by Bridgman and Davis (1998, 2004), later revised by Althaus et al. (2013), as involving the following eight stages:

1. **problem identification and agenda setting** – a problem is identified that captures the attention of the government and the larger community as requiring government action.
2. **policy analysis** – an issue is researched and analysed to inform a policy decision, often performed by the executive branch of government.
3. **policy instrument development** – policy instruments are designed or selected based on the most rational means to achieve a desired outcome.

4. **consultation** – to test the acceptability of a policy, discussions and proactive interactions are held with a range of actors, including the wider community.
5. **coordination** – once prepared, a policy is coordinated across government to secure funding and ensure consistency with other existing policies.
6. **decision** – one or more of the options debated and examined are decided on by a minister, the cabinet or other actor within government.
7. **implementation** – policy is then implemented by public sector or other, external institutions or organisations.
8. **evaluation** – after a policy is implemented, evaluation takes place to determine the policy's effectiveness and decide what action should follow.

Scholars have critiqued the stages model for its various limitations. One major criticism is that the stages model is underpinned by an assumption that decision making is rational and sequential. Policy issues are supposedly identified first, then an evidence-based solution is devised and implemented (Hill 2013). In reality, bureaucracies assigned to develop policy advice are inherently complex and political, and may make decisions that are more about organisational cultures and political struggles rather than optimal solutions (John 2012). In addition, the techniques used to inform rational decision making, such as cost-benefit analysis, face difficulties in calculating social costs and benefits, and policy makers always need to make value judgements about the desirability of policy projects (John 2012).

Another key criticism of the **rationalist policy cycle model** is that it ignores the complex political environment in which policymaking takes place (Howlett, Ramesh, and Perl 2009). This criticism, closely related to that of assumed rationality, highlights the lack of accuracy in defining the policymaking process as made up of separate, distinct stages. Instead, policymaking is complex and messy, and policy processes rarely have marked beginnings and endings (Hill 2013; Howlett, Ramesh, and Perl 2009; Knill and Tosun 2012; Sabatier and Jenkins-Smith 1993). In reality, distinct stages in the policy cycle may not be evident. They may overlap, be inseparable, in some cases may be missing entirely (Hallsworth, Parker, and Rutter 2011), or they might appear in a different order – for example, solutions might appear before problems (Cohen, March, and Olsen 1972).

As outlined, there is a robust body of policy study scholarship that points to the shortcomings of the stages model of the policy cycle, including that it is too simplistic and thus inaccurate and that it does not adequately capture the various factors that limit rational decision making. Various alternative theories or models of the cycle model have emerged, seeking to better reflect the complex reality of the policymaking process. Some common alternative models that have been used to explain the policymaking process include the incrementalist model, the garbage can model, the multiple-streams model and the advocacy coalition framework – each outlined briefly below.

The **incrementalist model** revised the assumptions of the rational model, arguing that decision making was not a fully rational process. Instead, only a limited amount of options are considered in the policy decision making process, and decision makers trade off policy aims to achieve a politically feasible outcome, resulting in incremental change (Lindblom 1959). The incrementalist model remains underpinned by the assumption that policy solutions are developed in response to identified problems, but it introduces the notion of bounded rationality.

The **garbage can model** was developed in response to observations that, in reality, public policy decision making rarely follows an orderly, sequential process as both the rationalist and incrementalist models assume. In this model, conceived by Cohen et al. (1972), the process in which policy aims are identified is unclear, and there is no distinct relationship between policy problems, analysis and solutions. Instead policy ideas, problems and possible solutions are dumped together, so that policies might be developed chaotically, influenced by various competing interests and agendas, often without full understanding of the policy issues it should address (Howlett, Ramesh, and Perl 2009; Zahariadis 2014).

The **multiple streams framework**, first conceptualised by Kingdon (2003), extended the garbage can model to explain how problems are identified and brought to the attention of policymakers at the agenda setting stage. This model views the policy process as the result of three sets of processes, or streams – the problem perception, the solutions, and public sentiments (change in government and the like) – which converge at certain times to create opportunities for agenda change (Tiernan and Burke 2002; Zahariadis 2014).

The **advocacy coalition framework (ACF)** model assumes that policy actors seek to make rational decisions, though often the rationality with which decisions are made is hindered by various complex factors. This model argues that the policy process is a long-term negotiation between coalitions of interests, policy brokers and political institutions that share a set of basic beliefs (Sabatier and Jenkins-Smith 1993; Sabatier and Weible 2014). These coalitions compete and interact to influence policy change.

In summary, there is a substantial literature that offers alternatives to the policy cycle as a model for the policy process. While the policy cycle may be regarded as a useful heuristic, and sometimes seen as the way that policy should be made, it is generally seen as a set of stages that are rarely followed in practice. These shortcomings are likely to be exacerbated when it is applied to developing country contexts which face a range of different constraints.

Much of the scholarship on the policy cycle and its alternative models has focused on Organisation for Economic Cooperation and Development (OECD) country contexts (Young 2005). The stages model conceptualised by Bridgman and Davis (Bridgman and Davis 1998), and later revised with Althaus et al. (2013) was developed for the Australian political context. Extensive work has also been dedicated to studying policymaking within the US political system (Kingdon 2003; Lasswell 1956; Parsons 1995), and to a lesser extent the UK (Hogwood and Gunn 1984). There remains a gap in the literature dedicated to understanding the policy process in developing country contexts. Various factors, including complex or troubled political contexts, and external interferences, may limit the application of policy cycle models in these contexts (Young 2005).

The relatively limited academic literature on the Indonesian policymaking process and the views of experts indicates that, due to factors such as the complexity of the Indonesian political context and the involvement of informal actors, the sequential model of the policy cycle may not reflect the Indonesian context very accurately. Datta et al. (2011, 69) observe that, in Indonesia, 'policymaking at the highest level of government is often complex, multi-factoral and non-linear'. Experts consulted in this present study emphasised the political nature of the policymaking process in Indonesia, where various competing interests and actors play a role in influencing the policy process. The Indonesian political system continues to develop and change rapidly in the post-decentralisation era, thus lacking the stability that rational models assume to be inherent in bureaucracies charged with formulating policy analysis. Often there may be gaps between policy issues and the policies used to respond to

them. Finally, key stages may be missing entirely. As Zhang (2015) observes in her study of local policymaking, evaluation is often not carried out, and public consultation is often incomplete, with certain interest groups favoured.

Many of the limitations and critiques of the stages model are evident, and indeed exacerbated, in Indonesia, where the political context is rapidly changing and various actors compete to influence the policy process. Despite not reflecting the Indonesian policymaking process, the stages model continues to be used as a tool to discuss the policy process, and to train civil servants (see Lembaga Administrasi Negara 2015). Its continued use indicates the value of a heuristic model to envision policymaking, as viewing the policy process as a series of stages can be helpful for identifying 'entry points' into the process, and for understanding the role of different types of actors (e.g. bureaucracy, ministers and cabinet, and the wider public) and different types of knowledge.

The remainder of the paper explores the context of policymaking in Indonesia in further depth, and considers alternative ways of describing and visualising the policy process to move toward a more accurate description. The following section outlines key features of the Indonesian context, before several examples of policymaking are described in detail. We will then return to the question of which, if any, model of the policy cycle best explains the policy process in Indonesia.

## 4. Policymaking in Indonesia: structures and traditions

This section of the paper offers a summary of the key contextual features of policymaking in Indonesia, considering both structures (the institutions and machinery of government) as well as practices informed by traditions. It assumes the reader is broadly familiar with the political history of Indonesia (from Dutch colonisation, through Suharto's 'New Order' regime, to more recent democratisation and decentralisation), but not necessarily with the workings of government and other policymaking actors. It describes the institutions and traditions that shape the policy process, which involves the creation, negotiation, revision and implementation of laws, regulations, guidelines, plans, and other governmental statements and actions. As Datta and co-authors (2016, 1), note, a wide range of organisations do policy work in Indonesia, 'such as government agencies, businesses, parliamentarians (and their staff), political parties, NGOs, media houses, universities, bi- and multi-lateral organisations, trade unions and other actors.' This section focuses predominantly on governmental institutions, while the role of non-governmental actors is introduced and explored further in following sections.

### Structure of government in Indonesia

#### Key national policy actors

Set up on independence in 1945 as a presidential system based on a written constitution, Indonesia has three key branches of government: the executive, legislature, and judiciary. The processes and outputs of policymaking vary among these branches, and at different levels within them, as well as between different policy sectors.

The Constitution gives executive power to the President – the head of state, who (since 2004) is elected directly by the people of Indonesia. The Cabinet, which consists of the President, Vice President and high-ranking ministers appointed by the President, is the key body in the executive. The role of the Cabinet is to formulate high-level policies for each of the 34 ministries in Indonesia's government. As Pramusinto (2016, 123) explains, 'Ministries translate the vision and missions of the President for five years, which are drawn from the pledges made during election campaigns into policies.'

Legislative power is held by the Indonesian parliament – the People's Consultative Assembly (*Majelis Permusyawaratan Rakyat* – MPR) – which has two chambers. The House of Representatives is called the People's Representative Council (*Dewan Perwakilan Rakyat* – DPR) and has 560 members. The Regional Representative Council (*Dewan Perwakilan Daerah* – DPD) has 132 seats – four members to represent each of the 33 provinces in Indonesia. The Regional Representative Council (DPD) is an advisory body that does not have a formal role in the law-making or budgeting processes; while the House of Representatives (DPR) has the authority to make and change laws, but in reality has to work with the executive to negotiate policy. Due to the large number of political parties in parliament, they are grouped into factions. Every member of parliament must be a member of a faction, which is the key mechanism for coordinating members' activities (rather than parties).

In Indonesia, parliament plays a major role in policymaking through the creation and amendment of laws, as well as in budget formulation and implementation, but it does not

work alone. Various stakeholders have input into the policymaking process, including development agencies, technical advisors, business people, civil sector organisations [CSOs], and academics. Government bills are usually drafted by a taskforce in the relevant ministry, 'which can include key decision-makers from the executive as well as technical experts from universities and CSOs' (Datta et al. 2011, 11). Each bill is required to be accompanied by an academic paper (*naska akademis*), which is supposed to contain 'a detailed explanation of the matters to be dealt with, including a breakdown of all clauses' (Datta et al. 2011, 11). However, previous research has found that formal processes for developing plans and policies in Indonesian government are not always followed in practice, and academic studies accompanying bills are sometimes lacking in substance (Datta et al. 2011, 13).

Both the executive and legislative branches of government must agree to a bill before it can become a law. In practice, most bills are introduced by the executive, then sent to a DPR committee or commission. Each member of parliament belongs to one of the DPR's 11 sectoral commissions, which have frequent contact with their respective ministries and agencies (Blöndal, Hawkesworth, and Choi 2009, 31). This is where most of the substantive deliberation on policy takes place (Sherlock 2012, 559). The sectoral commissions have on average 50 members each, elected proportionally according to each faction's share of seats in parliament. Members' commission affiliation is more important in practice than their party membership. 'In practical terms,' Sherlock (2012, 560) explains, 'DPR members know what their own commission is doing, but often have little or no knowledge or interest in the legislative and oversight work of other commissions.' Therefore, 'the most productive route to influence [policy] is to lobby or otherwise provide inducements to members of the relevant committee, especially the powerful ones, regardless of their party affiliation.' (Sherlock 2012, 561).

Once laws have been passed by parliament (DPR), then signed and formalised by the President, the executive produces implementing regulations. The regulations need to take into account other existing regulations, and sufficient budget and human resources also need to be found. Consequently, 'the time lag between enacting laws and the issuance of implementing regulations can take years', especially if the government considers the policy 'detrimental to its interests' (Pramusinto 2016, 131). While a bill introduced by the executive requires parliamentary approval to be enacted, the legislature's approval is not required for implementation guidelines, in the form of regulations, decrees and instructions. In practice, legislation is not always matched with an implementing regulation, and implementing regulations do not always align with legislation (expert consultation).

The judiciary also plays a role in the policy process, notably by blocking the implementation of laws deemed unconstitutional, and in issuing regulations that determine how laws are applied by the courts. The Constitutional Court can review or strike out laws, but not implementing regulations. Its establishment in 2003 and its independence from the government have created a 'legal pathway through which citizens and civil society activists have been able to challenge government policies they believe infringe human rights' (Rosser 2015, 84). There has been significant judicial reform since the fall of the authoritarian regime, beginning with the establishment of the Supreme Court as independent of the executive and legislative branches of government in 1999. Civil society organisations have played a significant role in the Supreme Court reforms, often with the support of international donors (Yon and Hearn 2016). Specific cases of judicial reform as policy are discussed in the next section of the paper, alongside examples of policy processes involving the other two branches of government – the executive and the legislature, often working closely together.

## Sub-national government in Indonesia

As well as governmental institutions at the national level, there are over 500 provincial, district and municipal governments in Indonesia. Since decentralisation occurred through a “big bang” in 1999, these local governments have played an increasingly important role in policymaking in Indonesia – although change has been incremental and inconsistent. The laws on local governance issued in 1999 devolved all governmental functions to local governments except for security and defence, foreign relations, fiscal and monetary policy, religious affairs and the legal system. Further legislation and implementing regulations were passed in 2001, 2004, 2007 and 2014 to enact the devolution of responsibility and resources to local governments. ‘Spatial equity’ is a priority of the current government, and a major tool for its redistribution policy is ‘fiscal allocation to local governments—including village funds introduced by Law 6/2014 on Villages’ (Sato and Damayanti 2015, 182). With the implementation of the new Village Fund Program, ‘the total government budget transferred to subnational governments has reached almost 37 percent’ (Datta et al. 2017, 34).

Provinces play a coordinating role, and can elect governors, but most power is now located at the district level. Like their national level counterparts, district governments have a legislature, executive and judiciary. Each district has a local house of representatives (DPRD) and an elected head of government (governor, regent or mayor), who presents drafts of the development budget and other plans to the DPRD for approval. The local parliaments have three functions: legislation, budgeting and monitoring. Each sub-national government has their own long, complex process of developing plans and budgets for each year, and administering these. Development planning and budgeting are generally considered not well coordinated at the sub-national level (expert consultation). Greater autonomy has nonetheless resulted in the emergence and diffusion of some local government innovations, such as health insurance schemes (Datta et al. 2017; Zhang and McRae 2015).

However, as Datta and co-authors (2017, 7) note, ‘after more than 30 years of centralized rule, there was very little capacity among local governments’ to manage large funds, identify priorities and challenges, and develop appropriate local plans and strategies. Despite relevant implementing regulations being issued, there are still areas of overlapping authority between the central government and provincial, district and city governments. Moreover, Pramusinto (2016, 159) adds, ‘decentralization is also hampered by the lack of trained officials at the provincial and district or city government levels.’ Zhang (2015) similarly finds that local governments rarely use research and data in policymaking, and when they do, it tends to mainly be statistical data for agenda setting, with research seldom commissioned to inform policy formulation.

Notably, decisions about whether programs and policies should be adopted or continued are not based on prior evaluations (Zhang 2015, iv). There is a lot of ‘copy-pasting’ of local strategies and plans, according to Sutmuller and Setiono (2011, 42) who also note, “There is no habit of involving stakeholders (practitioners, experts, universities, business community, civil society) [in local policymaking] and thus not accessing and benefitting from their knowledge in the policy formulation and policy decision-making process.’ There are thus likely to be significant differences in policymaking at the national and subnational levels. It was beyond the scope of this study to investigate these further, so policymaking at the subnational level remains an important focus area for future studies of policy processes in Indonesia.

## Traditions influencing policymaking in Indonesia

While the country has experienced rapid democratisation and decentralisation in recent years, the remnants of Dutch colonial rule and Suharto's authoritarian regime linger in government institutions and policymaking practice in Indonesia today. A significant legacy of the Napoleonic system left behind by the Dutch, and built on by the authoritarian approach of the New Order era, is 'an extensive bureaucratic machinery and a highly-codified legal system' – seen in the rigid hierarchy of laws and convoluted planning system still followed today (Datta et al. 2017, 50). Despite these rigid, hierarchical, formal processes, there is a lot of informal activity in policymaking. As Datta et al (2017, 8) summarise, in their review of Indonesia's recent political history, 'although the formal centralised system broke down, many of the existing political relationships and practices remained intact, resulting in a more competitive, complex and often confusing set of political relationships.'

This section of the paper considers such themes and contemporary activities in Indonesian government as 'traditions', inspired by Bevir and Rhodes' (2003) discussion of British political traditions. In addition to the traditions of centralised planning and budgeting, and a weak bureaucracy, Indonesian political culture such as consensus decision-making continues to shape policymaking practice today.

### Key policymaking practices: planning and budgeting

Along with legislation and regulation, development plans and budgets are major policy instruments in Indonesia. The compilation of these voluminous documents 'is a resource intensive process' (Datta et al. 2017, 34) that illustrates some of the cumbersome formal requirements and tensions between the different levels and branches of government in the policy process.

Under the authoritarian 'New Order' regime of President Suharto (1967-98), it may have been possible to identify a linear, rationalistic policy cycle. During that period, development planning was 'undisputedly dominated' by 'the economic ideas of the technocrats – a solid group of mainstream economic professionals and bureaucrats', known as the 'Berkeley mafia' (Boediono 2013, 8). Nonetheless, as Sherlock and Djani (2015, 7) point out, the goal for these US-trained economists 'was to legitimise the New Order government policies, while presenting the policies as being based on scientific and objective evidence', at a time when political science and sociological research in Indonesia was highly constrained. Since then, as experienced Indonesian policymaker Boediono (2013, 10) argues, 'Policy making has become more transparent, more publicly accountable, but also more challenging, more noisy and more time consuming.'

A legacy of the centralised authority of Suharto's authoritarian regime, development planning in Indonesia is seen as having fuelled Indonesia's impressive economic growth since independence (Blöndal, Hawkesworth, and Choi 2009, 12; Datta et al. 2017, 6). However, recent studies have found that policymakers treat planning and budgeting as administrative and compliance procedures, rather than as a process to discuss substantive policy issues and consider whether proposed solutions will actually improve outcomes (Zhang 2015, iii; Datta et al. 2017, 43). The planning and budgeting process is regulated by a fairly complex legal framework (see Datta et al. 2017, 34-36), which includes the following guidelines:



Formal rules governing the drafting of development plans suggest development planning should be (i) political: drawing on the agenda proposed by the president (or other democratically elected leaders); (ii) technocratic: based on data generated through scientific methods; (iii) participatory: incorporating the views of interest groups or stakeholders, including those from the executive, judiciary, legislature, society, private sector and non-governmental organisations (NGOs); (iv) top-down: centred on plans prepared by the president, ministries and agencies; and (v) bottom-up: founded on plans from the village, district and regional levels (Datta et al. 2011, 6).

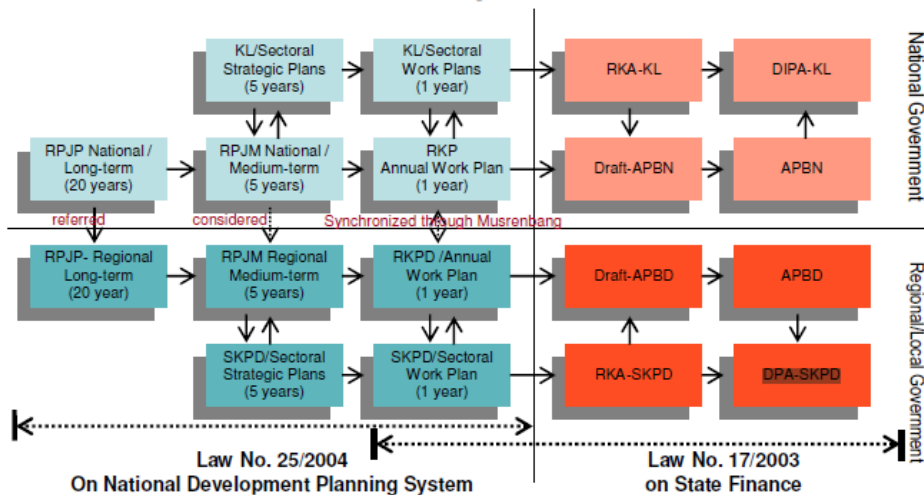

Figure 2 Integrated System of Planning and Budgeting (source: Datta et al. 2017, 35)

Long-term plans, developed for a 20-year period, are intended to guide all aspects of Indonesia’s economy and society. These then inform the medium-term plan, which coincides with the President’s five-year term and ‘functions to explicitly highlight the political priorities of the government and is in essence the policy agenda for the President’s term of office’ (Blöndal, Hawkesworth, and Choi 2009, 12). One of the main objectives of the National Medium Term Development Plan (RPJMN) 2015–2019, for instance, includes reducing inequality through increased productivity, development and poverty reduction measures. Mid-term development plans are similarly generated at the local level every five years: ‘Immediately after the election of a new Head of District, the [district] government commences the process of converting the successful candidate’s campaign manifesto ... into concrete policies in the LG’s Mid-Term Development Plan (RPJMD).’ (Zhang 2015, vi).

Development planning is supposed to be both bottom-up, in the form of consultative meetings (*musrenbang* – see below), and top-down. National development plans are drafted by the National Development Planning Board (Bappenas), and sub-national plans are drafted by Regional Development Planning Agencies (Bappeda) at provincial and district levels, in line with the overarching national development plan. Once a national-level plan is drafted, based on an evaluation of the most recent plan, and presented to a stakeholder forum (*musrenbang*), the head of Bappenas finalizes the plan and provides it to the President for approval, who then presents it to parliament. Subsequent annual development plans are developed by government ministries.

Despite the requirement for ‘bottom up’ planning, several researchers and commentators have observed gaps or weaknesses in the musrenbang process. Although these forums involve different levels of government and various civil society organisations – at least in urban areas - and they are important inputs into regional governments’ budgeting processes, ‘Musrenbang are principally an occasion for BAPPENAS to outline the draft government-wide work plan and to solicit any changes at the margins’ (Blöndal, Hawkesworth, and Choi 2009, 18). As Nurmandi (2012, 69) notes, ‘the Musrenbang agenda is more of a ceremonial forum’ and Bappenas is not required to disseminate the draft plan to citizens. Recent research on decentralized policymaking for KSI found the musrenbang: did not make useful information available to villages, sub-districts or technical agencies; rarely involved marginalized groups such as the poor or women; lacked clear criteria for decision-making; and were often bypassed by powerful actors. Notably, ‘Musrenbang were relatively short, announced at short notice, lacked competent facilitation and involved much speech making’ (Datta et al. 2017, 37).

Each year annual, provincial and district level government budgets are allocated, supposedly informed by the mid-term development plan. In practice, the process of budgeting is somewhat disconnected from the planning process, and involves political contestation as well as technical expertise. As Pramusinto (2016, 156) argues, ‘Budget allocation in Parliament calls for bargaining and intensive negotiation.’ The Budget Committee is a permanent part of the legislature, comprised of members taken proportionally from all factions in parliament. Indonesia’s annual budget formulation cycle can be divided into five stages:

1. establishing the level of resources available for the next budget (led by the Ministry of Finance and a committee of technical experts, February-June)
  2. establishing priorities for new programmes (led by BAPPENAS and culminating in a government-wide work plan issued by the President, March-May)
  3. pre-budget discussions with the Parliament (focused on the Budget Committee and sectoral commissions, mid-May – mid-June)
  4. finalisation of the budget proposal (led by the Ministry of Finance, mid-June to mid-August)
  5. preparing detailed budget implementation guidance (discussed and reviewed by Parliament’s sectoral commissions, August-October).
- (Blöndal, Hawkesworth, and Choi 2009)

It is a rigid and cumbersome process, yet is of crucial importance for policy implementation, since both the executive and public service depend on parliament’s decisions around budgeting (Pramusinto 2016, 156). Moreover, since the structure and timing of the process are so predictable, and information needs are relatively consistent, it is seen to offer regular opportunities for evidence-informed policymaking (Zhang 2015, vi). However, since plans and budgets are typically seen by civil servants ‘as outputs to produce rather than opportunities to discuss policy problems and strategies’ (Datta et al. 2017, iii), there is currently not much rigorous policy debate or analysis in planning and budgeting processes.

### **Weaknesses in policy capacity**

In the early 2000s, the Indonesian bureaucracy was considered among the lowest quality in the world (Datta et al. 2017, 6). Due to weaknesses in training, promotion and compensation, cumbersome reporting requirements, and a lack of significant bureaucratic reforms, the public service continues to be ‘widely seen as corrupt, bloated, inefficient and either incapable

or unwilling [to implement] policies set by the democratic government' (Datta et al. 2017, 19). This is a particular challenge for policymaking in Indonesia, as civil servants play an important role in the drafting and implementation of laws, regulations and guidelines, and by participating in 'regular planning, budgeting and accounting processes' (Datta et al. 2017, 19). A 2009 World Bank report (referred to by Nurmandi 2012, 35–36) revealed, in particular, weaknesses in 'coordinating the formulation and implementation of policies and programs across different branches, at both the central and local level'.

Law-making in Indonesia takes a long time and the government does not usually achieve its ambitious policy agenda. There were 284 laws on the national legislation programme (Prolegnas) from 2005 to 2009, and 247 laws on the 2010-2014 programme. However, as Pramusinto (2016, 122) notes, Parliament only has capacity to revise thirty laws a year despite 'its previous target of seventy laws a year.' There is also a very high turnover of parliamentarians, who are often not re-elected, which restricts 'the emergence of a cadre of experienced professional parliamentarians who have both policy depth and a good understanding of how to use parliamentary mechanisms and procedures to achieve policy outcomes.' (Sherlock 2012, 563).

Previous research for KSI found significant gaps in the capability of civil servants, who often lacked the expertise and incentives to make well informed policy (Sherlock and Djani 2015, 4). These problems were compounded by 'a bureaucratic culture of compliance with the letter of the law, poor staff training, pressure on civil servants to conform to existing practice within their particular ministry, and to obey their superiors.' (Sherlock and Djani 2015, 5). Despite efforts by initiatives such as KSI and The Australia Indonesia Partnership for Decentralisation to support evidence-informed policymaking in Indonesia, there continue to be significant gaps in the use of evidence and research in the policy process. Writing about the first 100 days of the government of President Joko Widodo (known as Jokowi), Damuri and Day (2015, 3–5) note, for instance, 'While some initiatives have been implemented with success, some seem to have been launched without enough preparation, consultation, or empirical evidence, and many have been poorly communicated.' On the other hand, there have also been some promising developments in Jokowi's approach to reforming government administration, notably through changes to the civil service law and the reorganisation of parliamentary staff (Sherlock and Djani 2015, 1-2).

Corruption continues to plague Indonesian politics and policy. Although anti-corruption activism is having some impact, Indonesia has consistently poor rankings on Transparency International's Corruption Perceptions Index. Between 2002 and 2013, at least 360 public officials, including Members of Parliament, police officers, bureaucrats, judges and mayors, along with bankers and businesspeople were jailed for corruption in Indonesia (Boediono 2013, 20). The illicit fundraising of the political elite, writes Marcus Mietzner (2015), has resulted in an oligarchical system of party politics and the misappropriation of state budgets. 'Systemic corruption in the bureaucracy deters people with talents and integrity from entering and thus further reduces the ability of the bureaucracy to perform effectively,' argues Boediono (2013, 22). This problem is compounded by 'a low salary remuneration system', which results in civil servants who 'are often compelled to undertake various activities to make ends meet' (Pramusinto 2016, 120). Fear of being accused of corruption also shapes the behaviour of public officials and those who come into contact with them. As Sherlock and Djani (2015, 7) write, in relation to the potential for strengthening policy processes by involving non-state actors: 'Many organisations remain reluctant to receive funds from the government because they want to maintain the independence of their institution, want to

avoid being drawn into complex bureaucratic processes and/or corrupt payments to officials.’ In relation to local government planning, Datta et al. observe that risk averse local civil servants prefer to “play it safe” by basing their annual plan and budget on the previous year’s documents. Local government officers worry that if they ‘try out new things’, they could be accused of ‘budget mismanagement, which might lead to corruption charges.’ (Datta et al. 2017, 42).

### Consensus style decision making

An important tradition in Indonesia, expressed in the 1945 Constitution and shaping policymaking today, is ‘the practice of making decisions by “deliberation to reach consensus” [*musyawarah untuk mencapai mufakat*],’ rather than majority voting (Sherlock 2012, 561). According to an OECD report, ‘It is most noteworthy that the budget – as amended by the Budget Committee – is enacted by consensus, rather than by majority voting’ (Blöndal, Hawkesworth, and Choi 2009, 27). This does not mean that every member of parliament must individually agree with each proposition discussed. Instead, informal negotiations and discussions are held among the various faction or party leaders behind closed doors. ‘In effect,’ as Sherlock (2012, 561) explains, ‘it is only the party leaders in the committee or plenary session who deliver the votes of their party: consensus is, in reality, an agreement amongst party leaders.’ This means that leaders of committees and parties have a lot more power than individual MPs, there is little transparency of decision-making, and there is less need to maintain party discipline or dialogue on policy issues than in other countries’ parliamentary systems. This also helps to explain why parliamentary debate is ‘notorious for ill-informed and irrelevant interventions by committee members, long repetitious speeches and ... inconsistent and contradictory policy stances’ (Sherlock 2012, 562).

### The role of non-governmental organisations

International development organisations and domestic civil society organisations play an influential role in some policy sectors, but have limited involvement in others. Donor agencies have notably influenced public policy changes through ‘the process of formulating regulatory frameworks, laws and other lower-tier regulations’ (Pramusinto 2016, 125). Recent research by Datta et al (2017, 48) demonstrates the influence of the World Bank on higher education policy, while Rosser (2015, 72) has ‘pointed to the way in which parents, teachers, and their NGO allies have been able to influence education policy-making through lobbying, demonstrations, the media, and strategic use of the court system.’ Since the fall of the New Order, a large number of civil society activists, including labour leaders, women activists, and human rights advocates, have also influenced policy by entering politics (Mietzner 2013). Where there are strong economic interests in certain policy issues, such as tobacco-control, groups like tobacco companies and farmers have exerted influence over policy by mobilising their financial resources, political connections, and organisational capacity; although they have been increasingly challenged by tobacco-control advocates based in health organisations, NGOs, universities and international organisations (Rosser 2015, 88). Some of the experts we consulted suggested that the policy cycle model was more likely to be followed in instances where an organisation with ‘technocratic’ expertise, such as the World Bank, was highly involved. However, instances of technocrats advancing a shared agenda in policymaking happens only occasionally (expert consultation; Boediono 2013).

## 5. Indonesian policymaking in practice: actual examples of policy processes

This section of the paper provides vignettes of specific policymaking processes from recent years in Indonesia. It includes instances of policymaking activities in different sectors by all three branches of government at the national level – the executive, legislature and judiciary – as well as highlighting input from non-governmental actors. The processes we studied each centre on a specific policy instrument, as briefly outlined below. The following section contains a discussion of the patterns observed, which constitute hypotheses for further investigation.

A more detailed visual depiction of the steps, actors and activities involved in developing each policy is presented on the following pages. They have been constructed based on descriptions of the policymaking process written by knowledge sector actors in Indonesia. The first example of the civil service law is based on a section of a recent paper for KSI (Datta et al. 2017). The other examples are based on the experience of PSHK, supplemented with relevant documentary sources. A process map was developed for each by identifying the main types of actors and activities involved, and arranging them in sequential order (see Key below). Sometimes different actors were involved in different activities simultaneously, and the maps sometimes show multiple streams of activity. The stages of the policy cycle model were used as an analytic framework to identify different types of activities.

This study had a limited scope and relied on research conducted by one of the organisations involved in the examples of policymaking (PSHK). This provided access to the 'black box' of policymaking - but is not an independently chosen set of examples, and has a strong focus on judicial reform. The individual policies were selected to reflect a mix of policy instruments and institutions, and were identified based on their relevance to KSI, who commissioned this work, and familiarity to PSHK, who carried out the primary research. The selected policies were often part of a bigger package of reform involving CSOs and international donors. They do not represent the broad range of policies developed in Indonesia. Sub-national policymaking, for instance, is not explored here, although it is an important level of government and warrants investigation in any follow-up studies.

The selected examples of policy instruments and associated policymaking process are:

### 1. **Civil Service Law (2014)**

As part of a broader agenda of bureaucratic reform, driven by subsequent governments and international donors, a new civil service law has been introduced. An academic team commissioned by the Domestic Affairs Committee prepared a draft bill that was first presented to Parliament in 2011. Widely debated within governmental and public forums, policymakers initially failed to agree on it, until one of the academic authors who drafted the bill published an influential newspaper column which spurred action by Cabinet in 2013. A watered down version of the bill was subsequently passed by Parliament and approved by the President in 2014. Although the Civil Service Commission was consequently set up and has been issuing its own regulations, broader implementation of the law stalled after the change of government in 2014. None of the implementing regulations required by the law had been passed at the end of 2016.

## **2. Supreme Court Regulation (12/2016) on Management of Traffic Violation Cases in Court**

A well-known problem in Indonesia, since it has been the topic of news media coverage and social media posts for some time, is the handling of traffic violation cases. In 2016, over three million cases - almost 96% of criminal cases handled by the courts - related to traffic violations. Supported by an international donor (Australia Indonesia Partnership for Justice), a civil society organisation (PSHK) worked with the Supreme Court Research and Development Center to review the situation and propose some solutions. The two organisations formed a research team, which conducted a study of district courts to understand the problem and identify potential responses. As well as drafting a regulation that was discussed and eventually approved by the Supreme Court, the research team conducted advocacy through the media and executive offices, which resulted in the handling of traffic violation cases being entered into the President's legal reform package in 2016. Working closely with the police and attorneys to coordinate their action, the Supreme Court is now implementing the new approach to online management of traffic cases, which is being monitored by PSHK with ongoing support from AIPJ.

## **3. Supreme Court Regulation (2/2015) on Small Claims Court**

Establishing a small claims procedure or court was part of the blueprint of judiciary reform issued by the Supreme Court in 2010, in order to reduce the cassation of small cases to the Supreme Court, and improve access to justice for the wider community. Following on that policy, the Supreme Court established a working group with support from AIPJ, which commissioned studies to inform and formulate draft regulation. After discussion in several working group meetings, the Supreme Court approved the draft regulation. The working group and research team then began to develop guidelines and materials to socialise the new approach to small claims with the public and the 300+ courts in Indonesia. To ensure the implementation of this procedure, and identify successes and challenges, the research team is also conducting monitoring and evaluation through observation and interviews with relevant stakeholders (courts and users of the procedure) for the working group.

## **4. Law on Persons with Disabilities (8/2016)**

When Indonesia ratified the international Convention on the Rights for Persons with Disabilities (CRPD), pressure grew to revise national legislation to treat disability as a human rights, rather than charity, issue. A coalition of community organisations promoting the rights of people with disabilities played a key role in law reform, taking the initiative to draft the Disability Bill, with people with disabilities, and succeeding in having the bill entered into the national legislation agenda. The bill, which was accompanied by an academic paper also produced by the disability community, was then discussed in, and passed by, Parliament. By the time it reached joint discussions with the government, the House no longer involved the community. When the House of Representatives' term ended in mid-2014, discussion of the bill was incomplete, and the legislative process had to start again with the new government in 2015. This time, the draft bill and academic paper were formulated by parliament, although still based on the community version. After three months of discussions, the House of Representatives and the Government agreed on the final draft of the Law on Persons with Disabilities, which was signed by the President in May 2016.

5. **Revision of Presidential Regulation (54/2010) on Research Procurement**  
 Indonesia suffers from a low level of scientific publications, and both research funding and government procurement have been identified as contributing issues. Stakeholders from government, universities and the wider research community have been pushing to revise the regulation on research procurement. Preliminary policy analysis and discussions led by KSI with stakeholders in 2016 identified potential amendments to the procurement provision of Presidential Regulation no. 54, year 2010. The government's procurement agency LKPP began drafting regulation in early 2017, with input from various government and community stakeholders. The bill was submitted to the executive for policy coordination and discussions, but as of May 2017, it had been returned to LKPP to be improved.
  
6. **Village Law (6/2014) and associated executive regulations**  
 Village development and community empowerment have long been discussed as part of the decentralisation agenda in Indonesia. The perceived need to update village law gained momentum following: a review of a 2004 law on local government by the Directorate General of Community Empowerment and Villages; a USAID sponsored study and consultation on village governance in 2008; and discussions in working meetings with the Ministry of Home Affairs in the House of Representatives in 2004-2009. Parliamentary discussion of the draft bill started after the President sent a letter to the House of Representatives to discuss the village legislation in January 2012. Two years later, following public hearings, a comparative study and parliamentary debates, the Village Law was passed by the House of Representatives, dramatically increasing the responsibilities and budgets of village administrations. The following year, the law became a political commodity during the 2014 parliamentary and presidential election campaigns. The incoming government included strategies for the implementation of the Village Law in its National Medium Term Development Plan 2015-2019. Various efforts to monitor its implementation are being conducted by civil society organisations (independent research institutions), with support from international donors (see, e.g., Antlöv, Wetterberg, and Dharmawan 2016).

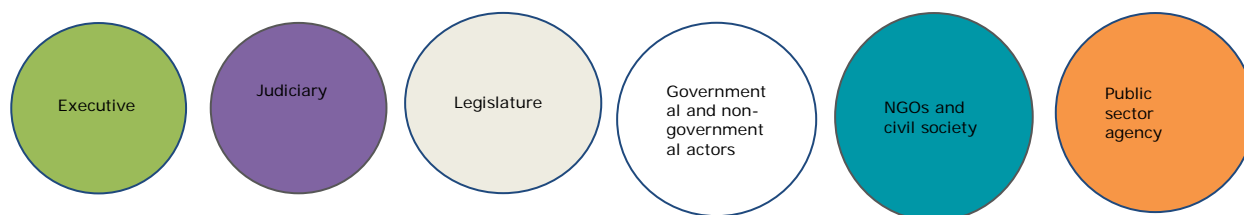
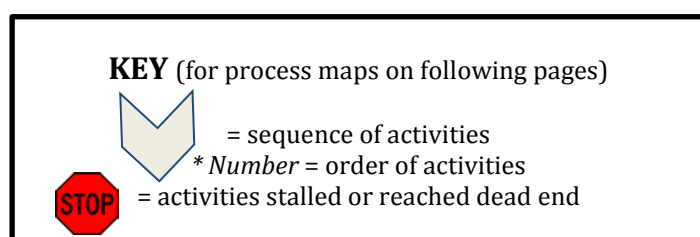

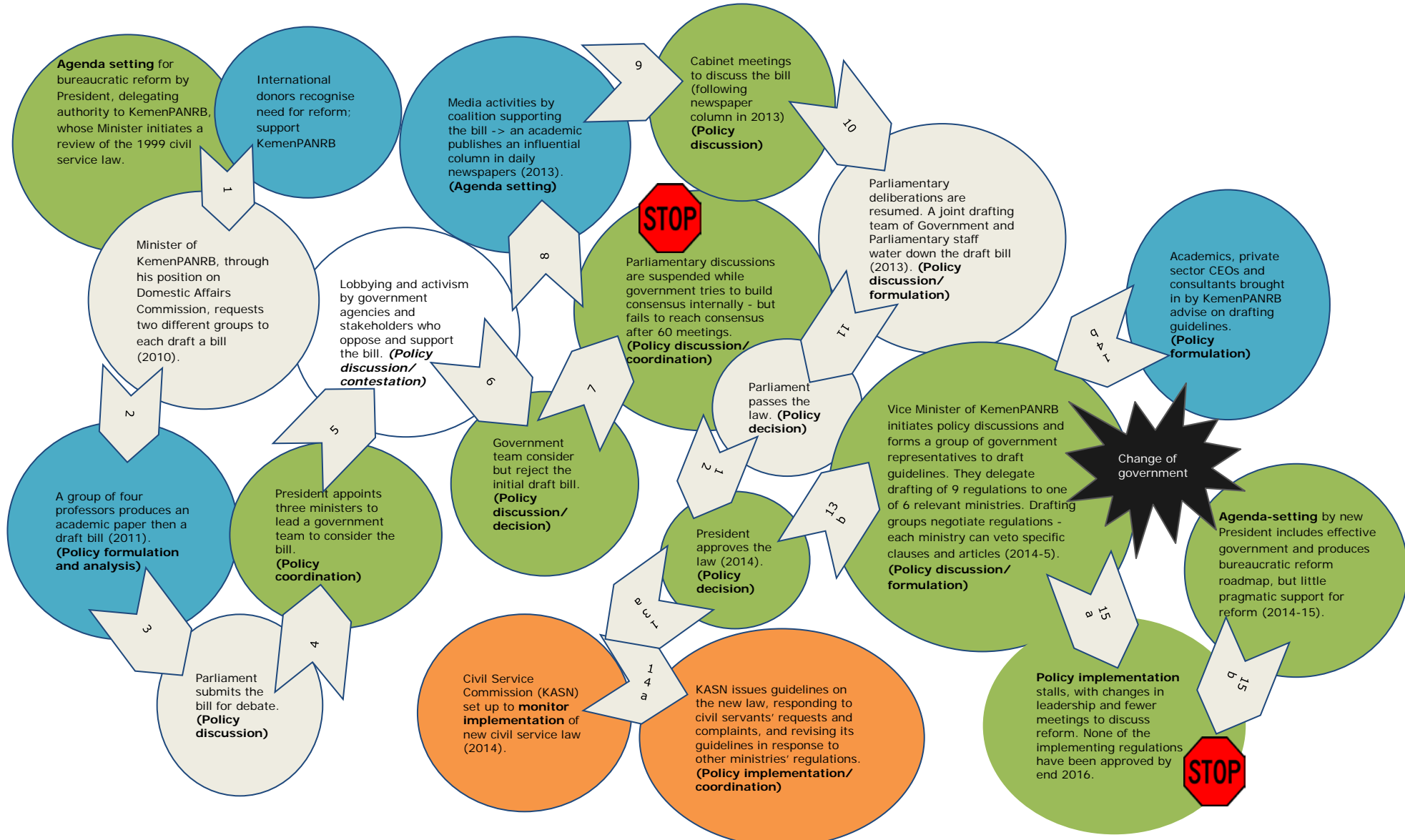

Figure 1. Civil service law reform



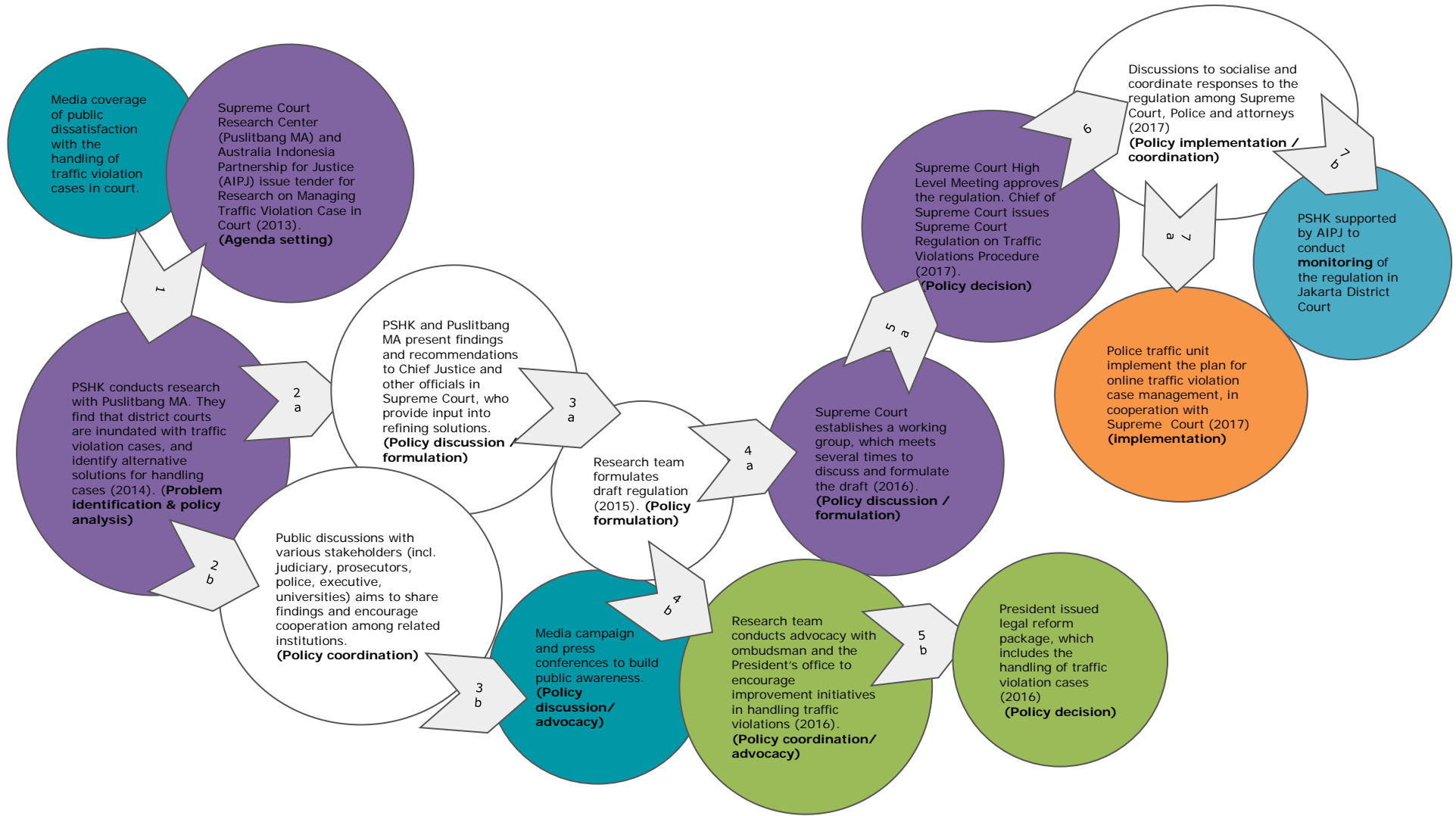

Figure 2. Supreme Court regulation on traffic violation cases

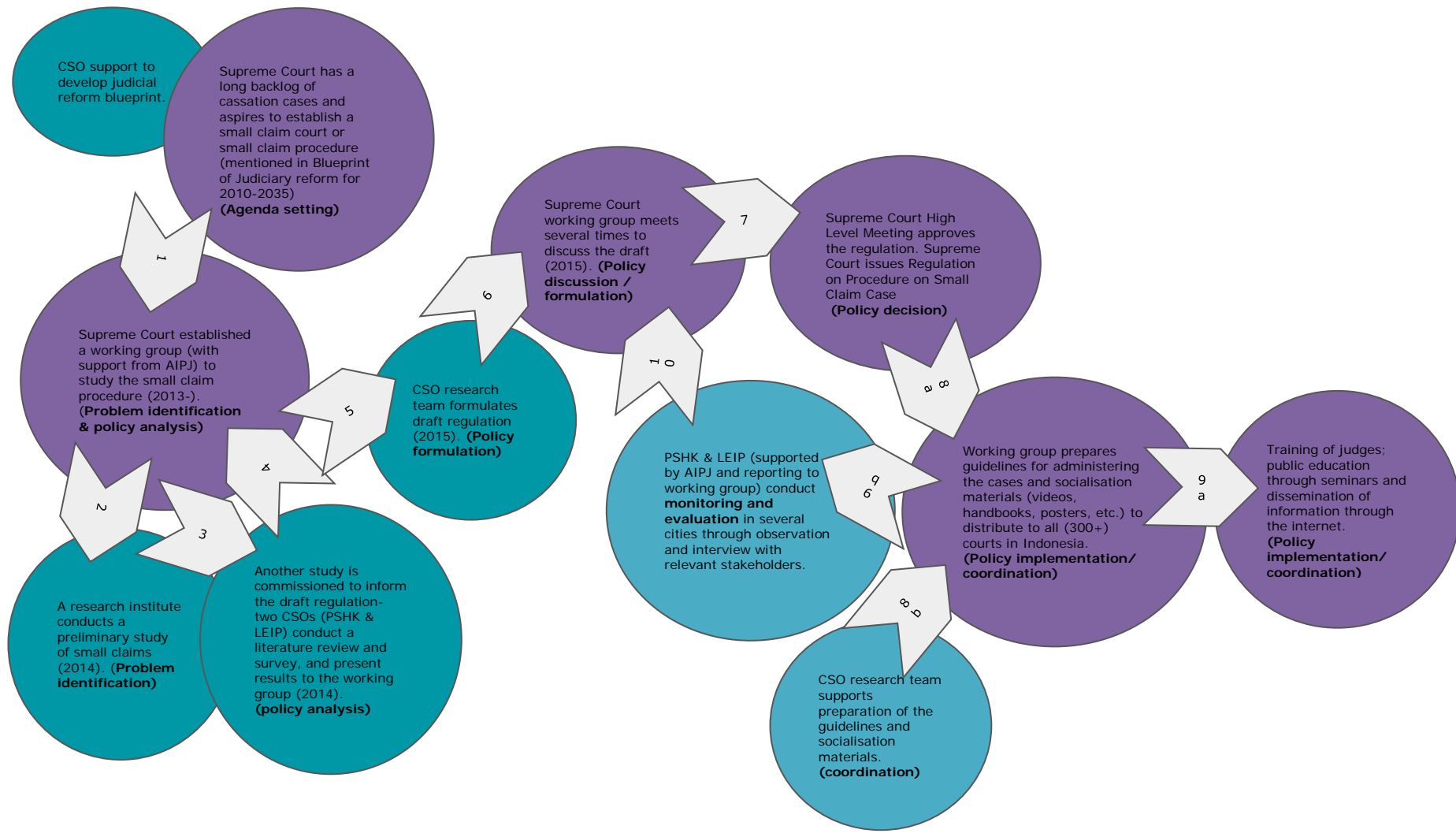

Figure 3. Supreme Court regulation on small claims procedure

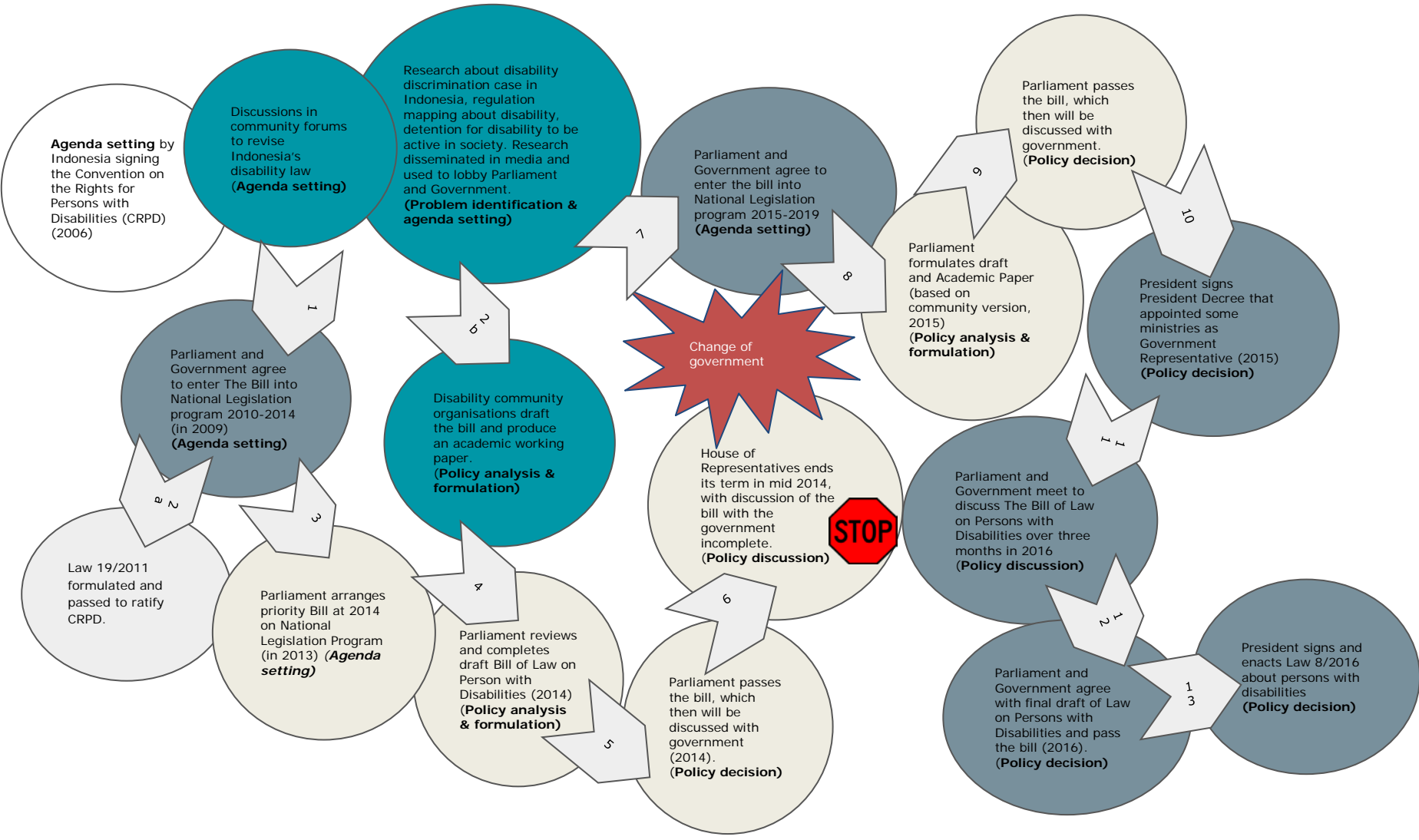

Figure 4. Law on Persons with Disabilities

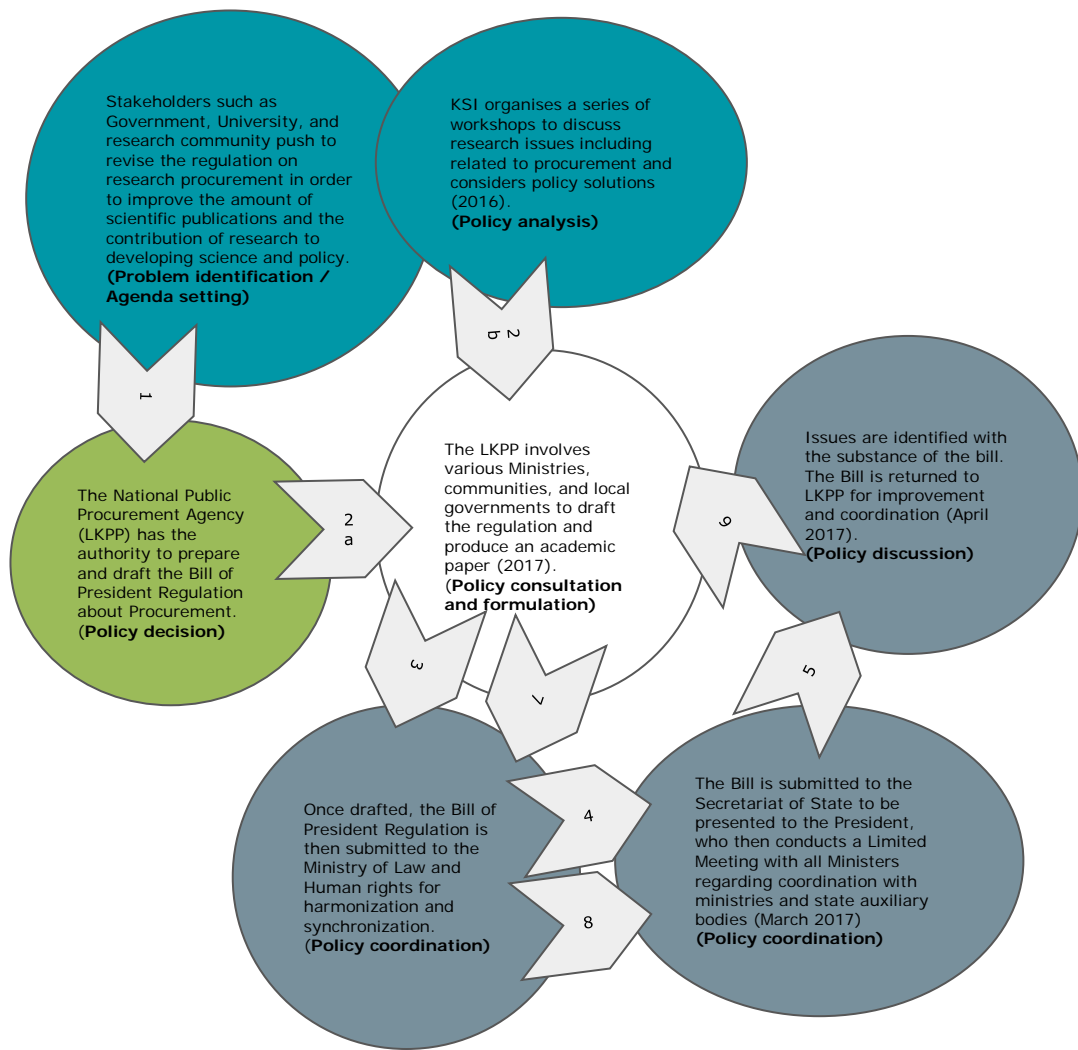

Figure 5. Presidential regulation on research procurement

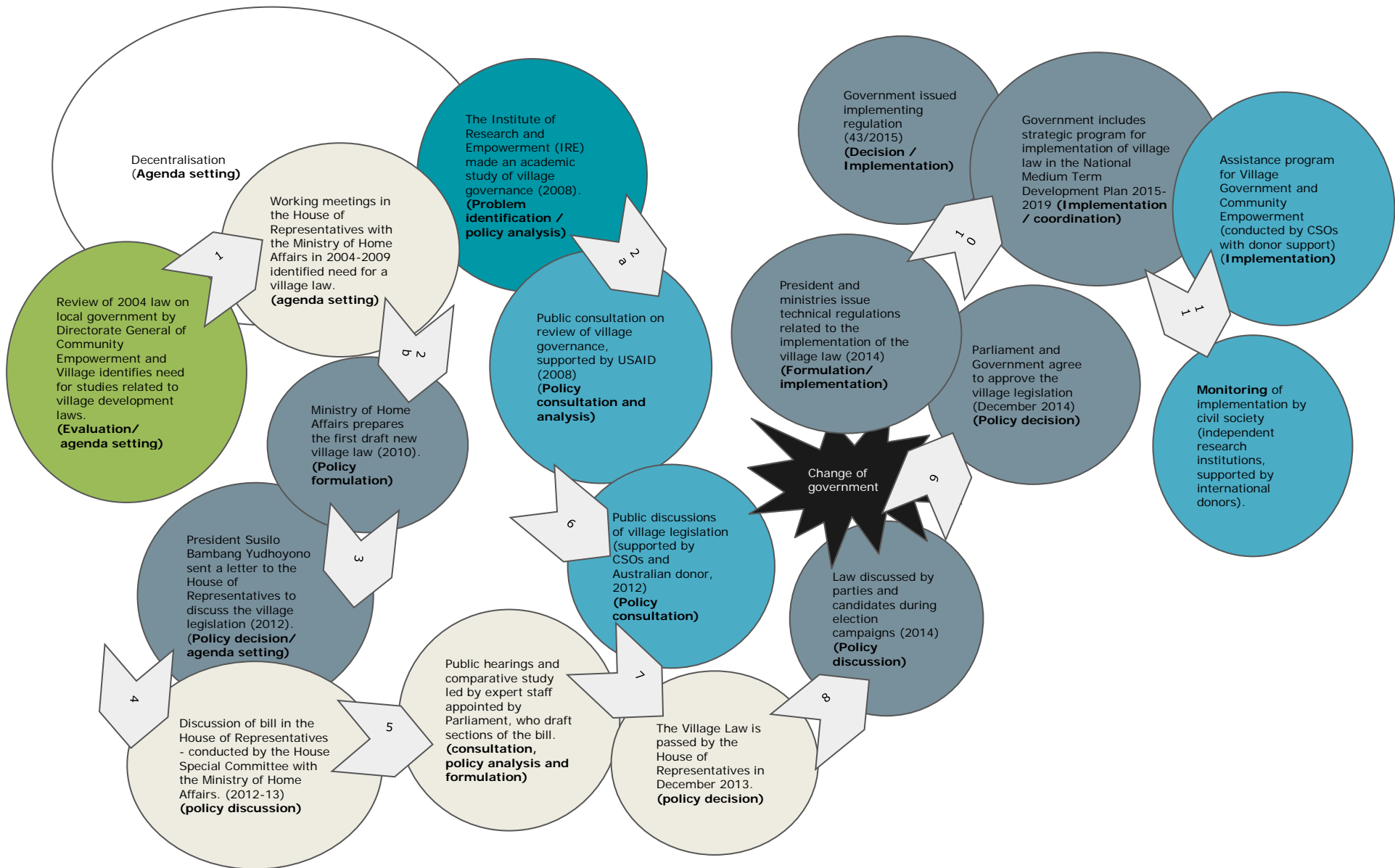

Figure 6. Village Law

## 6. Discussion: is there an Indonesian policy cycle?

This section discusses the patterns identified in the examples of policy processes presented on the preceding pages and considers whether a policy cycle can be observed. We discuss which activities within the academic conceptualisation of the policy cycle were evident in the examples we studied, as well as considering other aspects of the policy process that were notable in these cases.

### 1. Problem identification and agenda setting

The strongest pattern in the examples presented was an agenda-setting phase at the start of the policymaking process. For any public matter to become a policy issue, it first had to be identified and framed as a problem that required governmental attention and action. The problem was usually identified by non-governmental actors and often framed in relation to existing policy frameworks. Policy is never made on a blank slate; any policy issue can be connected to some existing policy responses. Existing responses will be seen either as inadequate to address the issue or as actually contributing to the problem.

Civil society organisations and the media played an important role in creating public awareness of the issues underpinning the selected examples. In several of these cases, international donors also played an important role in supporting the agenda-setting activities. Agenda setting did not end once the government was working on a policy, though. In instances such as the Supreme Court policy related to traffic violation cases, civil society actors continued advocacy work during policy development, in order to keep the issue on the agenda and generate public and political support for policy changes.

### 2. Policy analysis

There were inconsistent examples of policy analysis in the processes we studied. While the literature on the policy cycle suggests that policy analysis is often performed by the executive branch of government, and is usually the first activity after agenda setting, that was not the case here. In our examples, policy analysis was more likely to be performed by the legislative branch or non-governmental actors, and often at the same time as policy formulation. This was particularly true for judicial reforms that involved a civil society organisation funded by an international donor. Even when legal reform was happening through the executive or legislative branches of government, policy analysis and formulation were sometimes done by non-governmental actors, such as the academic team who produced the draft civil service bill. Although there is a legal requirement to produce an academic paper to inform the development of legislation, in at least some cases the academic paper appeared to be produced simultaneously or after a bill was first drafted. There was little evidence that the government would first research an issue and perform its own analysis before a policy decision would be made.

### 3. Policy instrument development

Another significant difference between the theoretical model of the policy cycle and actual examples of policymaking practice in Indonesia was that policy instruments did not seem to

be designed or selected based on the most rational means to achieve a desired outcome. There was little evidence of the government setting high level strategies then choosing instruments accordingly. In the examples we studied, the instruments seemed to be selected before any policy analysis or discussion took place. Policy analysis and discussions tended to focus on examining detailed drafts of legislation or regulation, rather than considering the different levers of influence the government could use to address an issue before selecting a particular instrument. An exception was judicial reform – hence the two track process that emerged in the example of traffic violation policy. In that case, the research team identified three possible solutions to the issue of traffic violation case management, and chose not to rely on the Supreme Court alone to develop the policy solution. While they were waiting for discussions to take place within the Supreme Court working group, the research team led a media campaign and held advocacy meetings with the ombudsman and the President’s office, which resulted in the issue becoming part of the President’s law reform package, as well as a new Supreme Court regulation.

There is perhaps an assumption among Indonesian policymakers and associated researchers that the logical place to make policy changes is through legislation or regulation. It is possible this observation is limited by our examples that mainly focus on law reform. There may, however, be alternative policy instruments that should be considered, especially when challenges of coordination and implementation are significant – as discussed below.

#### **4. Consultation**

The acceptability of a policy was generally not tested through a formal consultation held by the government with stakeholders or community members. Rather, discussions and proactive interactions were held with a range of actors throughout the policymaking process. Sometimes public hearings and media discussions were facilitated by government, but consultation more commonly occurred in one of two ways: internal government actors consulted with each other in policy discussions and negotiations; or public discussions with particular groups of community members or stakeholders were led by civil society organisations. Sometimes CSOs and government are operating policy processes in parallel, and identifying influences and connections between the two is not always obvious.

#### **5. Coordination**

Policy coordination is an important part of policymaking in Indonesia. Issues often cut across different ministries and branches of government. It is especially challenging to ensure consistency when there are so many regulations from different government bodies in Indonesia. This is discussed by Datta et al. (2017) in relation to the Civil Service Commission. Unlike in the theoretical model of the policy cycle, policy coordination does not necessarily wait until a policy document or instrument has been prepared. For instance, a meeting among different government ministries was convened to discuss coordinating the presidential regulation on research procurement before the draft was finalised.

#### **6. Decision**

There are many points of decision, which represent gates that a law must pass through before becoming an enacted policy. Each time a decision is made, such as the parliament passing a

bill or the president putting a law change on the national legislation agenda, this could be seen as the end of one mini-cycle and start of a new one. A change of government and related leadership changes can halt or stall a process.

Despite the formal separation of powers in Indonesia, the legislative and executive typically work together and try to reach agreement on policy issues, in accordance with the consensus style of decision making mentioned in the previous section. In practice this means lots of policy discussions, negotiation and consensus-building, especially while a policy issue or response is considered by government or parliament.

## **7. Implementation**

Even after a law has been approved by parliament and the president, often after a long period of discussion and negotiation, it may not be implemented completely. Issues of coordination also arise at the implementation phase, as a governmental body responsible for implementation must ensure its approach is consistent with other governmental regulations. A single policy may also require different forms and phases of implementation, and one aspect of a policy may be implemented (e.g. the establishment of the Civil Service Commission / KASN) while the broader approach stalls (e.g. no progress made on implementing regulations for bureaucratic reform).

## **8. Evaluation**

In theory, after a policy is implemented, evaluation should take place to determine the policy's effectiveness and decide what action should follow. Our process maps show almost no policy evaluation, except for a review of a local government law, and limited monitoring, mainly by non-governmental organisations (which was also mentioned in the expert consultation).

### **Alternative models of the policy process**

As several of the experts and sources consulted for this study commented (see, e.g., Rosser 2015), contestation is ever present in policymaking, and the 'advocacy coalition framework' (ACF) model is somewhat applicable to the Indonesian context. The selected policies were shaped by various competing interests and actors with differentiated power and ability to influence the policy process. Different groups formed coalitions in order to shape agendas and influence policy, but these coalitions were not stable or permanent. The ACF model assumes stable parameters and a set forum (policy subsystems) for policymaking, but in reality policymaking is often unstructured, and conditions change frequently, limiting the relevance of this model as an explanatory device.

The chaotic depiction of the 'garbage can' model may be more appropriate. The garbage can model, and subsequent 'multiple streams analysis', highlights the complex interaction of factors that bring an issue to prominence on the policy agenda and make governments receptive to agenda change (John 2012; Tiernan and Burke 2002; Howlett, Ramesh, and Perl 2009). These are not, however, useful heuristic devices for explaining Indonesian policymaking, since they do not help to describe patterns of activity or key actors and issues, such as the use of knowledge by civil society organisations in policy formulation and negotiations. In developing the policy process maps, we were not able to identify clear, short-



lived 'policy windows' where problem perceptions, policy solutions and political streams converged into opportunities for agenda change (Kingdon 2003; Tiernan and Burke 2002).

### **Concluding discussion: not quite a policy cycle**

As well as the variations of activities and common absence of certain stages, such as consultation and evaluation, it is clear from the discussion above and the process maps on the preceding pages that there is no common sequence of phases in policymaking that cuts across different types of policies and branches of government. Moreover, the process is clearly political and not purely rational. Political discussions and negotiations are an important part of policymaking in the legislative and executive branches of government. The process can be more straightforward when the Supreme Court is making regulations independently of other branches of government, but judicial reform also involves other governmental and non-governmental actors too.

Civil society organisations, international donors and the media play an important role, especially in agenda setting and sometimes in policy analysis, formulation and discussion. The only instances of monitoring identified in our examples were by CSOs. Sometimes policy entrepreneurs, such as PSHK, pursue different tracks simultaneously to increase the chances of a policy (e.g. traffic violation case management) being adopted and implemented. This observation challenges the findings of other research for KSI that suggested there is generally limited involvement of actors other than senior civil servants from the executive branch of government in policymaking (Datta et al. 2017).

## 7. Conclusion

This study concludes that it is not possible to identify a singular policy cycle in practice in Indonesia. Policymaking in Indonesia generally follows the process of agenda setting, then sub-processes of policy discussion/formulation/coordination/decision, often followed by implementation and sometimes by monitoring. However, abstracting these general patterns says little about how, why or where policies are made, or who gets to shape them.

The policy cycle is therefore not a suitable normative or descriptive framework for policymaking in Indonesia. Indeed, we would recommend that KSI discontinue their use of the term 'policy cycle', and instead refer to the 'policy process' when discussing policymaking in Indonesia. The policy cycle is a limiting framework that does not adequately explain the ways in which policy is made in Indonesia (and generally not in other nations either). This study did not identify an alternative heuristic device for describing the policy process and use of evidence in it, so this remains a question for further investigation.

This study has identified key aspects of policymaking that have not been as clear in research that predominantly focuses on structural dimensions, such as the political economy. By considering policymaking in Indonesia through the lenses of the policy cycle and political traditions, we have identified key actors, activities and patterns in the processes of policy development. Specific examples of policymaking illustrate the irregular and inconsistent ways in which policies are developed by the different branches of government in Indonesia. By combining this analysis of examples with a review of relevant literature on Indonesian government and development, this study has highlighted important trends in policymaking, such as the discussions and negotiations between the executive and the legislature, the significant role of non-governmental organisations in agenda setting and some policy analysis and formulation, and the limited formal opportunities for public participation and engagement in the policymaking process when led by government.

These observations are limited by the small scope of the study, but represent points for KSI and its knowledge sector partners to investigate further. They raise questions about the potential supply and demand of evidence, which, as other studies have shown, are likely to predominantly happen through informal channels and non-governmental actors. The limited opportunities for public and expert engagement in formal policy processes also represent challenges for addressing gender equality and social inclusion issues.

This is intended to be the first in a series of studies and analyses that throughout Phase 2 will help the KSI team and its stakeholders to understand gaps, challenges and opportunities in the evidence-informed policymaking process in Indonesia. This research series should help the KSI team and stakeholders understand issues of evidence use, coherence and coordination, as well as gender equality and social inclusion, in policy processes at the national and sub-national levels in Indonesia. As already noted, since no specific examples of sub-national policymaking were explored in this study, this remains an important area for future investigation.

This study could be built on and enhanced through the application of more in-depth research that applies learnings from developments in policy studies. This could include following the 'argumentative turn', which highlights the role of language and ideas in policy, and 'the practice turn', which sees policy as practice, or craft. Acknowledging the complexity, uncertainty, ambiguity and contingency in the world of policy, scholars taking an

argumentative approach to policy analysis typically point to the failure of rationalist methods borrowed from physical or natural science – and models like the ‘policy cycle’ – to explain action in the political realm (Fischer 2003; Hajer and Wagenaar 2003; Hajer and Laws 2008). The practice turn recognises the political context of policy, and the diffusion of power and knowledge in this realm. It similarly ‘undermines managerial or technical understandings of the policy process’, which, having placed too much emphasis on theory and models, have resulted in little knowledge about the daily activities of policy actors (Freeman, Griggs, and Boaz 2011, 132).

Studies of policy practice often show it to be messy, complicated and compromised. Because policy is made by a range of actors occupying different knowledge communities, it is rarely embodied in an easy-to-read, orderly structure (Spicker 2006; Schön 1983). Studies using argumentative and practice-oriented approaches in Indonesia could build an understanding of policy debates and practices in the context of specific policy communities (Shore and Wright 2011; Yanow 2011). Gaining a better understanding of the policy networks that exist in Indonesia could further uncover who is involved in the process, what evidence they use, and how they are able to shape the debates on particular issues (Lewis 2006). This could help KSI and the broader knowledge sector in Indonesia to strengthen their understanding of policymaking and identify windows of opportunity for knowledge mobilisation.

The findings in this paper reinforce observations on the concept of the policy cycle from Datta et al (2017, 57), in a recent report for KSI: ‘policymaking is a far messier and unpredictable process in which many actors are involved and where the separation of stages is difficult to maintain.’ This should come as no surprise to KSI (2016, 6), whose Phase 2 Concept Note states, ‘The program does not advocate the use of any rigid policy model, recognising that the reality of policymaking is frequently far from any stylised cycle.’ Nonetheless, as in other countries, people continue to speak about the policy cycle as though it may exist ‘out there’, or could be created if we try hard enough. This paper should help to dispel that myth. While some of the different stages of the policy cycle can be identified when analysing policies in Indonesia, the general process of policymaking cannot accurately be represented as a series of distinct but interrelated stages, underpinned by the rationality of applied problem solving. Further investigation into the practice of policymaking should help to create a more nuanced picture of how policies are really made.

## 8. References

- Althaus, Catherine, Peter Bridgman, and Glyn Davis. 2013. *The Australian Policy Handbook*. Crows Nest, N.S.W.: Allen & Unwin.
- Antlöv, Hans, Anna Wetterberg, and Leni Dharmawan. 2016. 'Village Governance, Community Life, and the 2014 Village Law in Indonesia'. *Bulletin of Indonesian Economic Studies* 52 (2): 161–83. doi:10.1080/00074918.2015.1129047.
- Bevir, Mark, and Rod A.W. Rhodes. 2003. *Interpreting British Governance*. London: Routledge.
- Blöndal, Jón R., Ian Hawkesworth, and Hyun-Deok Choi. 2009. 'Budgeting in Indonesia'. 2009/2. OECD Journal on Budgeting. OECD.
- Boediono, Professor. 2013. 'The Challenges of Policy Making in a Young Democracy: The Case of Indonesia'. 14.01. Economics Discussion Paper. Perth: Australia.
- Bridgman, Peter, and Glyn Davis. 1998. *Australian Policy Handbook*. 2nd ed. Sydney: Allen & Unwin.
- Cairney, Paul. 2012. *Understanding Public Policy*. Hampshire: Palgrave Macmillan.
- Cohen, Michael D., James G. March, and Johan P. Olsen. 1972. 'A Garbage Can Model of Organizational Choice'. *Administrative Science Quarterly* 17 (1): 1–25. doi:10.2307/2392088.
- Colebatch, Hal K. 2005. 'Policy Analysis, Policy Practice and Political Science'. *Australian Journal of Public Administration* 64 (3): 14–23.
- Damuri, Yose R., and Creina Day. 2015. 'Survey of Recent Developments'. *Bulletin of Indonesian Economic Studies* 51 (1): 3–27. doi:10.1080/00074918.2015.1016565.
- Datta, Ajoy, Medelina K. Hendytio, Vidhyandika Perkasa, and Tobias Basuki. 2016. 'The Acquisition of Research Knowledge by National-Level Decision Makers in Indonesia'. Working Paper 16. Jakarta: Knowledge Sector Initiative. [http://www.ksi-indonesia.org/files/1480577570\\$1\\$WFZL\\$.pdf](http://www.ksi-indonesia.org/files/1480577570$1$WFZL$.pdf).
- Datta, Ajoy, Harry Jones, Vita Febriany, Dan Harris, Rika Kumala Dewi, Leni Wild, and John Young. 2011. 'The Political Economy of Policy-Making in Indonesia: Opportunities for Improving the Demand and Use of Knowledge'. Working Paper 340. London: Overseas Development Institute.
- Datta, Ajoy, Rachma Nurbani, Gema Satria, Hans Antlov, Ishkak Fatonie, and Rudy Sabri. 2017. 'Policy, Change and Paradox in Indonesia: Implications for the Use of Knowledge'. Jakarta: Knowledge Sector Initiative.
- Durose, Catherine, and Liz Richardson. 2016. *Designing Public Policy for Co-Production: Theory, Practice and Change*. Policy Press.
- Fischer, Frank. 2003. *Reframing Public Policy: Discursive Politics and Deliberative Practices*. Oxford: Oxford University Press.
- Freeman, Richard, Steven Griggs, and Annette Boaz. 2011. 'The Practice of Policy Making'. *Evidence & Policy* 7 (2): 127–36.
- Hajer, Maarten, and David Laws. 2008. 'Ordering through Discourse'. In *The Oxford Handbook of Public Policy*, edited by Michael Moran, Martin Rein, and Robert E. Goodin, 251–63. Oxford: Oxford University Press.
- Hajer, Maarten, and Hendrik Wagenaar. 2003. *Deliberative Policy Analysis Understanding Governance in the Network Society*. New York: Cambridge University Press.
- Hallsworth, Michael, Simon Parker, and Jill Rutter. 2011. 'Policy Making in the Real World'. <https://www.instituteforgovernment.org.uk/publications/policy-making-real-world>.
- Hill, Michael J. 2013. *The Public Policy Process*. 6th ed. Harlow, England: Pearson Education.
- Hogwood, Brian W., and Lewis A. Gunn. 1984. *Policy Analysis for the Real World*. Oxford: Oxford University Press.

- Howlett, Michael, and Ishani Mukherjee. 2017. *Handbook of Policy Formulation*. Edward Elgar Publishing.
- Howlett, Michael, M. Ramesh, and Anthony Perl. 2009. *Studying Public Policy: Policy Cycles & Policy Subsystems*. Oxford: Oxford University Press.
- Huckel Schneider, Carmen, and Fiona Blyth. 2017. 'Challenges of Integrating Evidence into Health Policy and Planning: Linking Multiple Disciplinary Approaches'. *Public Health Research & Practice* 27 (2). doi:10.17061/phrp2721719.
- Hughes, Rhidian. 1998. 'Considering the Vignette Technique and Its Application to a Study of Drug Injecting and HIV Risk and Safer Behaviour'. *Sociology of Health & Illness* 20 (3): 381-400. doi:10.1111/1467-9566.00107.
- John, Peter. 2012. *Analyzing Public Policy*. 2nd ed. Routledge Textbooks in Policy Studies. New York: Routledge.
- Kingdon, John W. 2003. *Agendas, Alternatives, and Public Policies*. 2nd ed. New York : Longman. <http://trove.nla.gov.au/work/20260586>.
- Knill, Christoph, and Jale Tosun. 2012. *Public Policy: A New Introduction*. New York: Palgrave Macmillan.
- Lasswell, Harold D. 1956. *The Decision Process: Seven Categories of Functional Analysis*. College Park: University of Maryland.
- Lembaga Administrasi Negara. 2015. 'Modul Pelatihan - Analisis Kebijakan'. Knowledge Sector Initiative.
- Lewis, Jenny M. 2006. 'Being around and Knowing the Players: Networks of Influence in Health Policy'. *Social Science & Medicine* 62 (9): 2125-36. doi:10.1016/j.socscimed.2005.10.004.
- Lindblom, Charles E. 1959. "The Science of "Muddling Through"". *Public Administration Review* 19 (2): 79-88. doi:10.2307/973677.
- Mietzner, Marcus. 2013. 'Fighting the Hellhounds: Pro-Democracy Activists and Party Politics in Post-Suharto Indonesia'. *Journal of Contemporary Asia* 43 (1): 28-50. doi:10.1080/00472336.2012.735919.
- . 2015. 'Dysfunction by Design: Political Finance and Corruption in Indonesia'. *Critical Asian Studies* 47 (4): 587-610. doi:10.1080/14672715.2015.1079991.
- Nurmandi, Achmad. 2012. 'Model and Practice of Strategic Policy Process in Indonesia: Case Study Strategic Management in Indonesian Central Government (2009-2012)'. *Journal of Management and Strategy* 3 (4): 65. doi:10.5430/jms.v3n4p65.
- Parsons, D. W. 1995. *Public Policy: An Introduction to the Theory and Practice of Policy Analysis*. Aldershot, UK: Edward Elgar.
- Pramusinto, Agus. 2016. 'Weak Central Authority and Fragmented Bureaucracy: A Study of Policy Implementation in Indonesia'. In *The Role of the Public Bureaucracy in Policy Implementation in Five ASEAN Countries*, edited by Jon S.T. Quah, Online, 98-170. Cambridge University Press.
- Rosser, Andrew. 2015. 'Contesting Tobacco-Control Policy in Indonesia'. *Critical Asian Studies* 47 (1): 69-93. doi:10.1080/14672715.2015.997083.
- Sabatier, Paul A., and Hank C. Jenkins-Smith. 1993. *Policy Change and Learning : An Advocacy Coalition Approach*. Theoretical Lenses on Public Policy. Boulder, Colo.: Westview Press.
- Sabatier, Paul A., and Christopher M. Weible, eds. 2014. *Theories of the Policy Process*. 3 edition. Boulder, CO: Westview Press.
- Sato, Yuri, and Arie Damayanti. 2015. 'Survey of Recent Developments'. *Bulletin of Indonesian Economic Studies* 51 (2): 165-88. doi:10.1080/00074918.2015.1061909.

- Schmidt, Vivien A. 2010. "Taking Ideas and Discourse Seriously: Explaining Change Through Discursive Institutionalism as the Fourth "New Institutionalism"". *European Political Science Review* 2 (1): 1–25.
- Schön, Donald A. 1983. *Reflective Practitioner: How Professionals Think in Action*. Aldershot: Ashgate.
- Sherlock, Stephen. 2012. 'Made by Committee and Consensus: Parties and Policy in the Indonesian Parliament'. *South East Asia Research* 20 (4): 551–68. doi:10.5367/sear.2012.0121.
- Sherlock, Stephen, and Luky Djani. 2015. 'Update on Constraints in the Enabling Environment to the Provision of Knowledge in Executive and Legislative Government'. Diagnostic Study. Jakarta: Knowledge Sector Initiative.
- Shore, Cris, and Susan Wright. 2011. 'Conceptualising Policy: Technologies of Governance and the Politics of Visibility'. In *Policy Worlds: Anthropology and the Analysis of Contemporary Power*, edited by Cris Shore, Susan Wright, and Davide Però, 1–26. New York: Berghahn Books.
- Simon, Herbert A. 1996. *The Sciences of the Artificial*. Cambridge, MA: MIT Press.
- Spicker, Paul. 2006. *Policy Analysis for Practice: Applying Social Policy*. Bristol: Policy Press.
- Sullivan, Larry, ed. 2009. 'Public Policy'. In *The SAGE Glossary of the Social and Behavioral Sciences*, by Larry Sullivan, 424–25. Thousand Oaks: SAGE Publications. doi:10.4135/9781412972024.n2076.
- Sutmuller, Paul M., and Ivo Setiono. 2011. 'Diagnostic on Evidence-Based Public Policy Formulation under Decentralisation'. Jakarta: AusAID and BAPPENAS. [https://www.academia.edu/8137816/Diagnostic\\_on\\_Evidence-based\\_Public\\_Policy\\_Formulation\\_under\\_Decentralisation](https://www.academia.edu/8137816/Diagnostic_on_Evidence-based_Public_Policy_Formulation_under_Decentralisation).
- The Knowledge Sector Initiative. 2016. 'Phase 2 Concept Note'.
- Tiernan, Anne, and Terry Burke. 2002. 'A Load of Old Garbage: Applying Garbage-Can Theory to Contemporary Housing Policy'. *Australian Journal of Public Administration* 61 (3): 86–97. doi:10.1111/1467-8500.00287.
- Yanow, Dvora. 2011. 'A Policy Ethnographer's Reading of Policy Anthropology'. In *Policy Worlds: Anthropology and the Analysis of Contemporary Power*, edited by Cris Shore, Susan Wright, and Davide Però, 300–313. New York: Berghahn Books.
- Yon, Kwan Men, and Simon Hearn. 2016. 'Laying the Foundations of Good Governance in Indonesia's Judiciary'. London: ODI. <https://www.odi.org/publications/10496-laying-foundations-good-governance-indonesia-s-judiciary>.
- Young, John. 2005. 'Research, Policy and Practice: Why Developing Countries Are Different'. *Journal of International Development* 17 (6): 727–34. doi:10.1002/jid.1235.
- Zahariadis, Nikolas. 2014. 'Ambiguity and Multiple Streams'. In *Theories of the Policy Process*, edited by Paul A. Sabatier and Christopher M. Weible, 3 edition. Boulder, CO: Westview Press.
- Zhang, Diane. 2015. 'Do Local Governments in Indonesia Produce Evidence-Based Policies?' Jakarta: Australia Indonesia Partnership for Decentralisation.
- Zhang, Diane, and Dave McRae. 2015. 'Policy Diffusion: A Four District Study of the Replication of Health Insurance (Jamkesda) and Bosda in Indonesia'. Jakarta: Australia Indonesia Partnership for Decentralisation.

## Annex: list of experts consulted

Dr Rachael Diprose, Lecturer in Development Studies, School of Social and Political Sciences, The University of Melbourne

Prof Vedi Hadiz, Professor of Asian Studies, The Asia Institute, The University of Melbourne

Dr Krishna Hort, Senior Consultant (technical advisor), Nossal Institute for Global Health, University of Melbourne

Prof Denny Indrayana, Professorial Fellow, Melbourne Law School

Prof Tim Lindsey, Director, Centre for Indonesian Law, Islam and Society – Melbourne Law School

Dr Dave McRae, Senior Research Fellow, The Asia Institute, The University of Melbourne

Prof Andrew Rosser, Professor of South East Asian Studies, The Asia Institute, The University of Melbourne

Dr Stephen Sherlock, Adjunct Associate Professor, University of New South Wales Canberra